

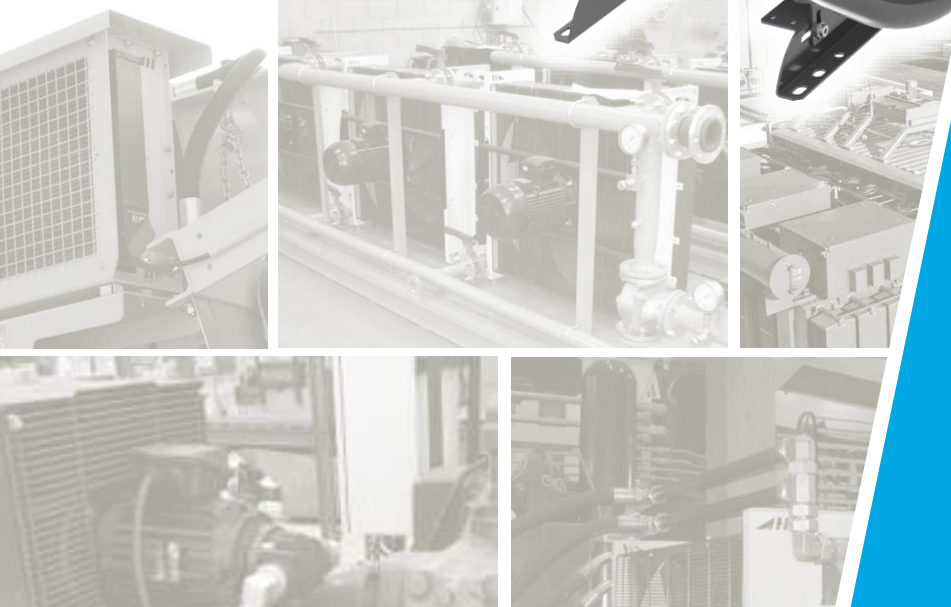

Thermal Systems

OFFLINE Coolers / Air Cooled Range

CC-2 Rail 6 – 32 gpm



OFFLINE Coolers

Air Cooled Range / CC-2 Rail / 6 – 32 gpm



General Data and Details

The oil / air coolers of our CC series are autonomous cooling systems with an integrated circulation pump. They work as a separate cooling unit or as a filter cooling unit with an adequate filter. The benefits of such circulation coolers are a constant cooling performance and a higher durability, because there are no pressure vibrations or peaks in the cooler unit.

Conditions of use:

Maximum oil temperature: 176°F, maximum air temperature: 122°F. Motors can be used up to an altitude of 4900 ft. For other conditions of use please contact our engineers.

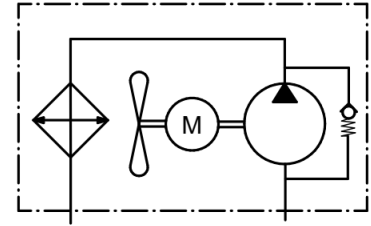

Connection

The **asa** rail system is the first worldwide flexible mounting and connection system for air blast heat exchangers. It gives you the free choice of the connector direction through turnable ports. The rail slots in the radiator are the frame structure not only for connecting the ports, also for various possible mounting arrangements such as bypass systems, mounting of the cooler to aggregates, measurement devices and much more. Please contact us to discover the huge potential of this system for your application.

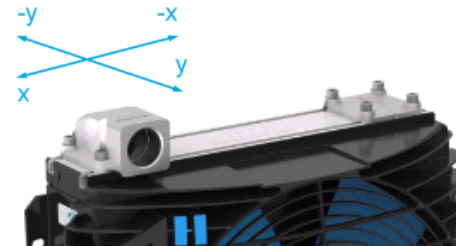

Scale Drawing

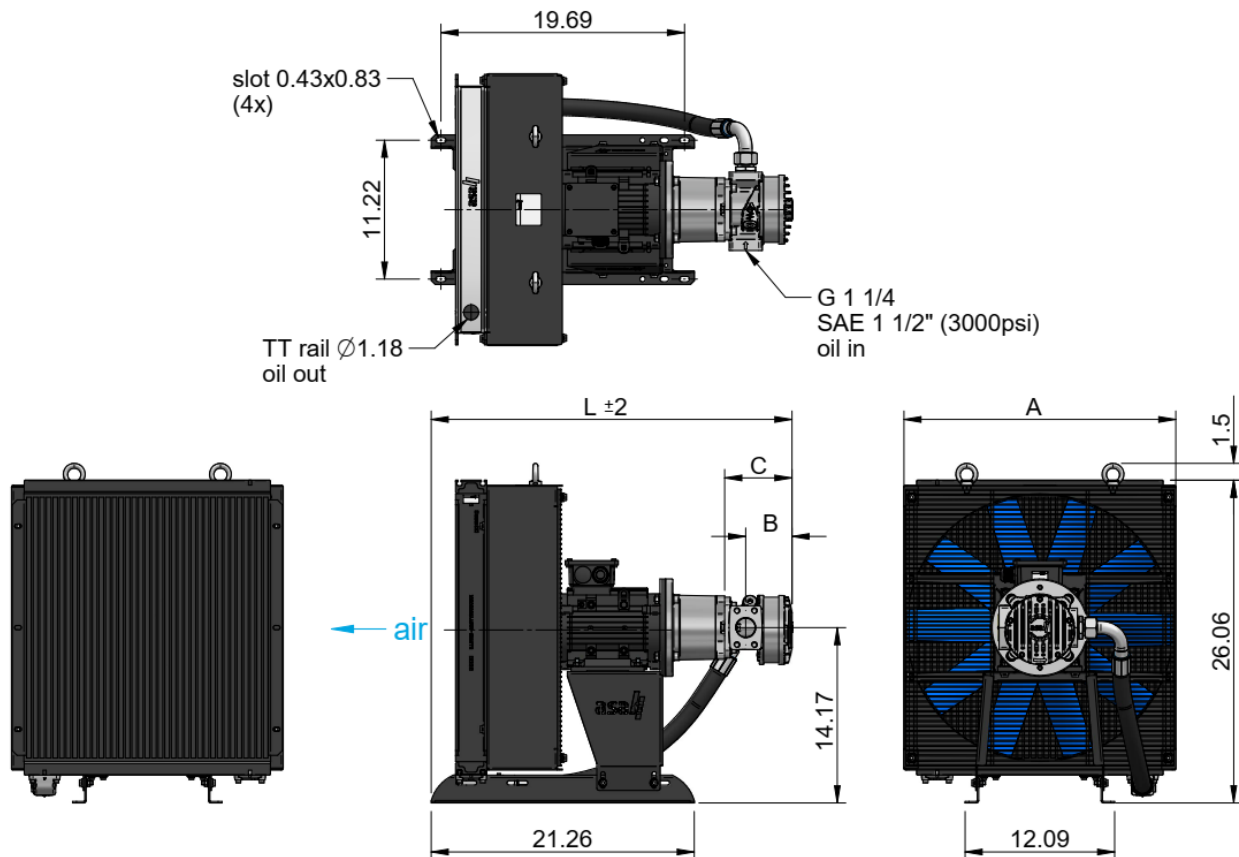

This data sheet and the corresponding scale drawings are to be used as a general guideline and technical overview of our products. Please contact us if more exact information is needed. As we are constantly improving our products, their characteristics, dimensions and weights may also change, although we do our best to incorporate these changes continually. asa assumes no liability for any information therein, any errors, omissions, misprints, nor any direct or indirect damages, losses or costs resulting therefrom. Any cooling performances and general technical values indicated in this catalogue are measured at a test bench according to asa testing procedures or calculated, based on such tests. They represent a basis for your product selection. Due to different conditions in testing and application environments the performance may also vary by +/- 15%. All sound values are determined in accordance with ISO 9614-2, DIN EN ISO 11203 accuracy class 3 or Machinery Directive 2006/42/EG and are A-rated. At some of the performance data, possible differences to competition data are possible. The reason to that are no existing standardized testing procedures on individual subjects, e.g. for cooling performance measurements. Therefore, we recommend all products to be checked under the system operating conditions. This is also true of vibrations and mechanical stress as well as for pressure peaks and thermal stress and any other relevant factors. General tolerances according to DIN ISO 2768-M, General tolerances for casted parts according to EN ISO 8062-3 (DCTG 10). Tolerances for rubber parts are according to ISO 3302-1 (class M4-F+C). The tolerances of welding seams are defined by quality group D according to EN ISO 10042, if it is not specified on the actual scale drawing or data sheet. Any form of liability is excluded for the information included in this datasheet. All details and calculation values are checked to the best of our ability, but these do not ensure any intrinsic product properties; due to the wide-ranging possible applications, it is advised that all technical data herewith included be confirmed through testing carried out by the end-user. asa technology Produktions- und Vertriebs GmbH reserves the right to modify the product without any separate notification. This refers to both technical data and the product itself. Furthermore, it is herewith specified that the datasheet does not substitute the corresponding scale drawings, assembly and installation guidelines, nor the operating instructions.

DD-CC-2-TT-Rail-us-rev0 © asa technology, May 2024 page 2/8

OFFLINE Coolers

Air Cooled Range / CC-2 Rail / 6 – 32 gpm



Dimensions

order number	description	A	B	C	L	weight
		[in]	[in]	[in]	[in]	[lbs]
ASATT25RA69C2U00	TT 25 rail 460V 1.8HP 6-pol 20cc	21.97	2.91	4.61	28.35	137
ASATT25RA69C4U00	TT 25 rail 460V 1.8HP 6-pol 40cc	21.97	3.35	5.04	28.78	139
ASATT25RA69C8U00	TT 25 rail 460V 1.8HP 6-pol 80cc	21.97	4.21	5.91	29.65	143
ASATT36RA69C8U00	TT 36 rail 460V 1.8HP 6-pol 80cc	28.98	4.21	5.91	30.47	166
ASATT36RA69C4U00	TT 36 rail 460V 1.8HP 6-pol 40cc	28.98	3.35	5.04	29.61	159
ASATT36RA6AC8U00	TT 36 rail 460V 2.4HP 6-pol 80cc	28.98	4.21	5.91	31.61	190
ASATT25RA49C4U00	TT 25 rail 460V 2.4HP 4-pol 40cc	21.97	3.35	5.04	28.78	141
ASATT25RA49C6U00	TT 25 rail 460V 2.4HP 4-pol 60cc	21.97	3.78	5.47	29.21	143
ASATT25RA4AC8U00	TT 25 rail 460V 3.6HP 4-pol 80cc	21.97	4.21	5.91	30.79	161
ASATT36RA49C4U00	TT 36 rail 460V 2.4HP 4-pol 40cc	28.98	3.35	5.04	29.61	163
ASATT36RA4AC8U00	TT 36 rail 460V 3.6HP 4-pol 80cc	28.98	4.21	5.91	31.61	179
ASATT36RA4BC4U00	TT 36 rail 460V 4.9HP 4-pol 40cc	28.98	3.35	5.04	30.75	188

Technical Data

order number	description	displacement	oil flow (Qp)	motor power	motor current	rotation	air flow	noise level
		[in ³ /rotation]	[gpm]	[hp]	[A]	[rpm]	[SCFM]	[dB(A)]
ASATT25RA69C2U00	TT 25 rail 460V 1.8HP 6-pol 20cc	1.22	6	1.80	2.6	1135	2828	66
ASATT25RA69C4U00	TT 25 rail 460V 1.8HP 6-pol 40cc	2.44	11	1.80	2.6	1135	2793	71
ASATT25RA69C8U00	TT 25 rail 460V 1.8HP 6-pol 80cc	4.88	21	1.80	2.6	1135	2775	73
ASATT36RA69C8U00	TT 36 rail 460V 1.8HP 6-pol 80cc	4.88	21	1.80	2.6	1135	3146	76
ASATT36RA69C4U00	TT 36 rail 460V 1.8HP 6-pol 40cc	2.44	11	1.80	2.6	1135	5002	72
ASATT36RA6AC8U00	TT 36 rail 460V 2.4HP 6-pol 80cc	4.88	21	2.40	3.5	1140	4985	78
ASATT25RA49C4U00	TT 25 rail 460V 2.4HP 4-pol 40cc	2.44	17	2.40	3.4	1735	4384	84
ASATT25RA49C6U00	TT 25 rail 460V 2.4HP 4-pol 60cc	3.66	25	2.40	3.4	1735	4331	84
ASATT25RA4AC8U00	TT 25 rail 460V 3.6HP 4-pol 80cc	4.88	32	3.60	4.6	1720	4331	84
ASATT36RA49C4U00	TT 36 rail 460V 2.4HP 4-pol 40cc	2.44	17	2.40	3.4	1735	4861	87
ASATT36RA4AC8U00	TT 36 rail 460V 3.6HP 4-pol 80cc	4.88	32	3.60	4.6	1720	4790	87
ASATT36RA4BC4U00	TT 36 rail 460V 4.9HP 4-pol 40cc	2.44	17	4.90	6.2	1720	7760	89



This data sheet and the corresponding scale drawings are to be used as a general guideline and technical overview of our products. Please contact us if more exact information is needed. As we are constantly improving our products, their characteristics, dimensions and weights may also change, although we do our best to incorporate these changes continually. asa assumes no liability for any information therein, any errors, omissions, misprints, nor any direct or indirect damages, losses or costs resulting therefrom. Any cooling performances and general technical values indicated in this catalogue are measured at a test bench according to asa testing procedures or calculated, based on such tests. They represent a basis for your product selection. Due to different conditions in testing and application environments the performance may also vary by +/- 15%. All sound values are determined in accordance with ISO 9614-2, DIN EN ISO 11203 accuracy class 3 or Machinery Directive 2006/42/EG and are A-rated. At some of the performance data, possible differences to competition data are possible. The reason for that are no existing standardized testing procedures on individual subjects, e.g. for cooling performance measurements. Therefore, we recommend all products to be checked under the system operating conditions. This is also true of vibrations and mechanical stress as well as for pressure peaks and thermal stress and any other relevant factors. General tolerances according to DIN ISO 2768-M, General tolerances for casted parts according to EN ISO 8062-3 (DCTG 10). Tolerances for rubber parts are according to ISO 3302-1 (class M4-F+C). The tolerances of welding seams are defined by quality group D according to EN ISO 10042, if it is not specified on the actual scale drawing or data sheet. Any form of liability is excluded for the information included in this datasheet. All details and calculation values are checked to the best of our ability, but these do not ensure any intrinsic product properties; due to the wide-ranging possible applications, it is advised that all technical data herewith included be confirmed through testing carried out by the end-user. asa technology Produktions- und Vertriebs GmbH reserves the right to modify the product without any separate notification. This refers to both technical data and the product itself. Furthermore, it is herewith specified that the datasheet does not substitute the corresponding scale drawings, assembly and installation guidelines, nor the operating instructions.

DD-CC-2-TT-Rail-us-rev0 © asa technology, May 2024 page 3/8

OFFLINE Coolers

Air Cooled Range / CC-2 Rail / 6 – 32 gpm



Performance

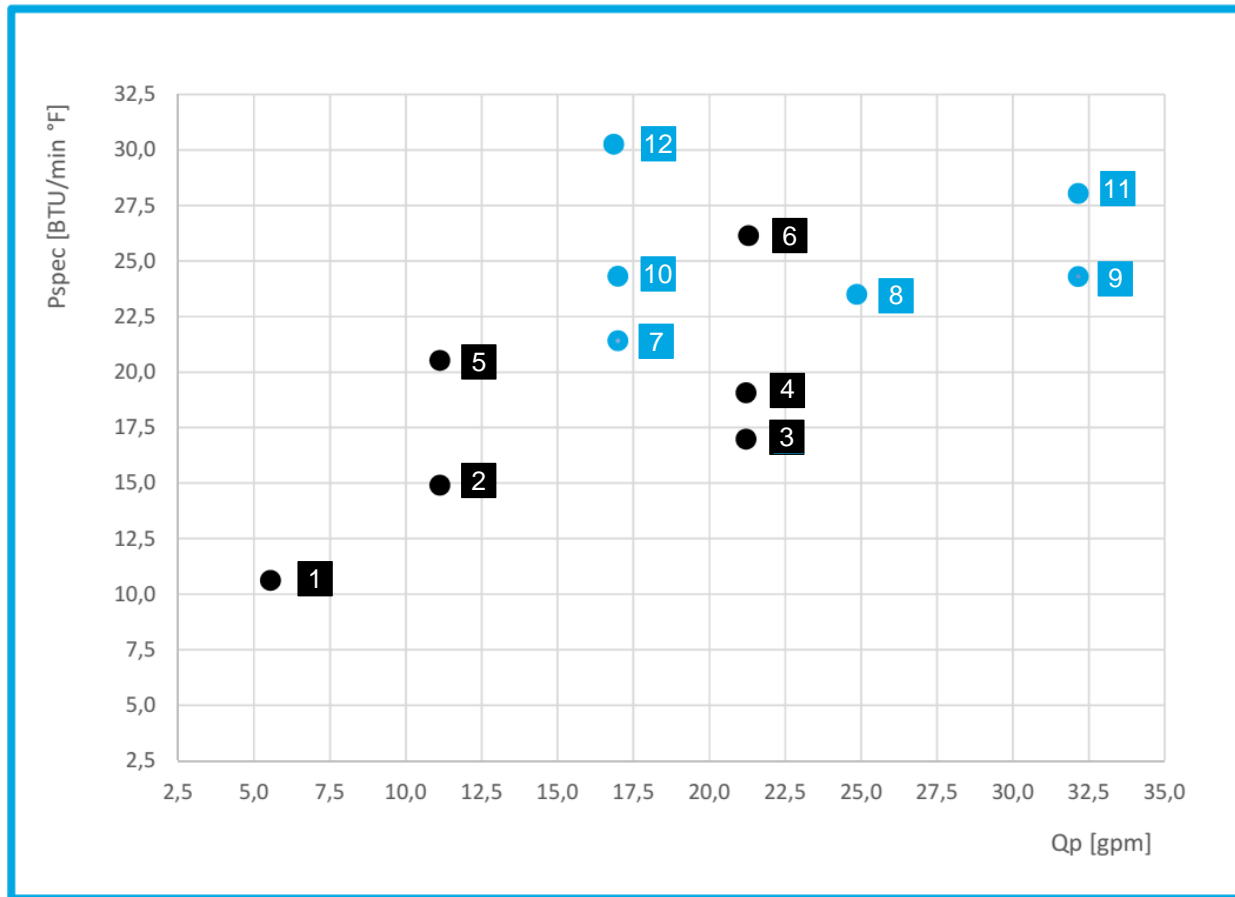

Technical Data

order number	description	oil flow (Qp)	spec. cooling power (Pspec)	performance
		[gpm]	[BTU/min °F]	see diagram
ASATT25RA69C2U00	TT 25 rail 460V 1.8HP 6-pol 20cc	6	10.6	1
ASATT25RA69C4U00	TT 25 rail 460V 1.8HP 6-pol 40cc	11	14.9	2
ASATT25RA69C8U00	TT 25 rail 460V 1.8HP 6-pol 80cc	21	17.0	3
ASATT36RA69C8U00	TT 36 rail 460V 1.8HP 6-pol 80cc	21	19.1	4
ASATT36RA69C4U00	TT 36 rail 460V 1.8HP 6-pol 40cc	11	20.5	5
ASATT36RA6AC8U00	TT 36 rail 460V 2.4HP 6-pol 80cc	21	26.1	6
ASATT25RA49C4U00	TT 25 rail 460V 2.4HP 4-pol 40cc	17	21.4	7
ASATT25RA49C6U00	TT 25 rail 460V 2.4HP 4-pol 60cc	25	23.5	8
ASATT25RA4AC8U00	TT 25 rail 460V 3.6HP 4-pol 80cc	32	24.3	9
ASATT36RA49C4U00	TT 36 rail 460V 2.4HP 4-pol 40cc	17	24.3	10
ASATT36RA4AC8U00	TT 36 rail 460V 3.6HP 4-pol 80cc	32	28.0	11
ASATT36RA4BC4U00	TT 36 rail 460V 4.9HP 4-pol 40cc	17	30.3	12

This data sheet and the corresponding scale drawings are to be used as a general guideline and technical overview of our products. Please contact us if more exact information is needed. As we are constantly improving our products, their characteristics, dimensions and weights may also change, although we do our best to incorporate these changes continually. asa assumes no liability for any information therein, any errors, omissions, misprints, nor any direct or indirect damages, losses or costs resulting therefrom. Any cooling performances and general technical values indicated in this catalogue are measured at a test bench according to asa testing procedures or calculated, based on such tests. They represent a basis for your product selection. Due to different conditions in testing and application environments the performance may also vary by +/- 15%. All sound values are determined in accordance with ISO 9614-2, DIN EN ISO 11203 accuracy class 3 or Machinery Directive 2006/42/EG and are A-rated. At some of the performance data, possible differences to competition data are possible. The reason to that are no existing standardized testing procedures on individual subjects, e.g. for cooling performance measurements. Therefore, we recommend all products to be checked under the system operating conditions. This is also true of vibrations and mechanical stress as well as for pressure peaks and thermal stress and any other relevant factors. General tolerances according to DIN ISO 2768-VL, General tolerances for casted parts according EN ISO 8062-3 (DCTG 10). Tolerances for rubber parts are according to ISO 3302-1 (class M4-F+C). The tolerances of welding seams are defined by quality group D according to EN ISO 10042, if it is not specified on the actual scale drawing or data sheet. Any form of liability is excluded for the information included in this datasheet. All details and calculation values are checked to the best of our ability, but these do not ensure any intrinsic product properties; due to the wide-ranging possible applications, it is advised that all technical data herewith included be confirmed through testing carried out by the end-user. asa technology Produktions- und Vertriebs GmbH reserves the right to modify the product without any separate notification. This refers to both technical data and the product itself. Furthermore, it is herewith specified that the datasheet does not substitute the corresponding scale drawings, assembly and installation guidelines, nor the operating instructions.

DD-CC-2-TT-Rail-us-rev0 © asa technology, May 2024 page 4/8

OFFLINE Coolers

Air Cooled Range / CC-2 Rail / 6 – 32 gpm



Design

radiator material	aluminum
radiator air fin shape	wavy
pump type	gerotor
pump material (housing)	aluminum
sheet metal material	coated steel

Pressure

max. working pressure	80 psi
-----------------------	--------

Compatibility

max. kinematic viscosity:	up to 2315 SSU at 100°F (depending on motor power)
suitable fluids	mineral oil acc. to DIN51524

Connection (1 5/16-12UNF)

ILLZATT53U16U00	requires 1pc per cooler (included with cooler)
-----------------	--

Options

asa rail connector	ILLZATT53U20U00 (1 5/8-12 UN)
temperature switch	ILLZTH5069KU00 (122°F) ILLZTH4765KU00 (122°F) ILLZTH6065KU00 (140°F)
rail filter	integrated spin on filter (page 6)
motor data	alternative voltages, frequencies, protection levels, etc on request
temperature bypass	for asa rail system (page 7)

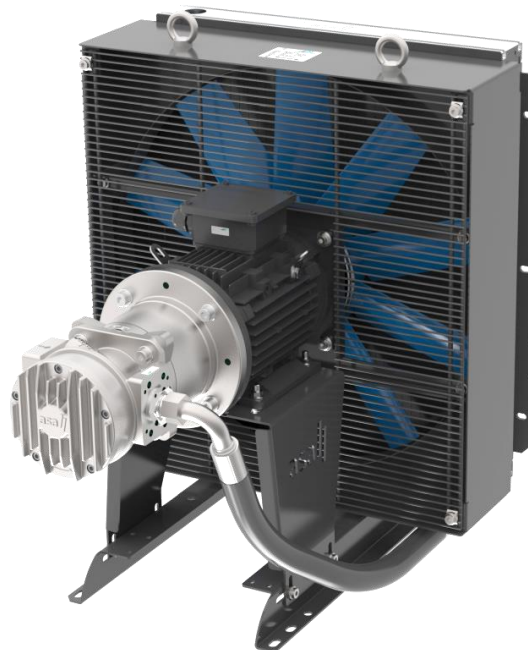

This data sheet and the corresponding scale drawings are to be used as a general guideline and technical overview of our products. Please contact us if more exact information is needed. As we are constantly improving our products, their characteristics, dimensions and weights may also change, although we do our best to incorporate these changes continually. asa assumes no liability for any information therein, any errors, omissions, misprints, nor any direct or indirect damages, losses or costs resulting therefrom. Any cooling performances and general technical values indicated in this catalogue are measured at a test bench according to asa testing procedures or calculated, based on such tests. They represent a basis for your product selection. Due to different conditions in testing and application environments the performance may also vary by +/- 15%. All sound values are determined in accordance with ISO 9614-2, DIN EN ISO 11203 accuracy class 3 or Machinery Directive 2006/42/EG and are A-rated. At some of the performance data, possible differences to competition data are possible. The reason to that are no existing standardized testing procedures on individual subjects, e.g. for cooling performance measurements. Therefore, we recommend all products to be checked under the system operating conditions. This is also true of vibrations and mechanical stress as well as for pressure peaks and thermal stress and any other relevant factors. General tolerances according to DIN ISO 2768-M, General tolerances for casted parts according to EN ISO 8062-3 (DCTG 10). Tolerances for rubber parts are according to ISO 3302-1 (class M4-F+C). The tolerances of welding seams are defined by quality group D according to EN ISO 10042, if it is not specified on the actual scale drawing or data sheet. Any form of liability is excluded for the information included in this datasheet. All details and calculation values are checked to the best of our ability, but these do not ensure any intrinsic product properties; due to the wide-ranging possible applications, it is advised that all technical data herewith included be confirmed through testing carried out by the end-user. asa technology Produktions- und Vertriebs GmbH reserves the right to modify the product without any separate notification. This refers to both technical data and the product itself. Furthermore, it is herewith specified that the datasheet does not substitute the corresponding scale drawings, assembly and installation guidelines, nor the operating instructions.

DD-CC-2-TT-Rail-us-rev0 © asa technology, May 2024 page 5/8

OFFLINE Coolers

Air Cooled Range / Options

System for Rail Series



The H-Set is an optional system to integrate another hydraulic set to the asa rail system. The H-Set currently offers 2 sizes of kits to mount a spin on filter to the cooler application. This is a very compact and cost efficient integration. This system can also be combined with various other filters or the shown configurations. Contact us for further options and assistance to select the optimal product for you.

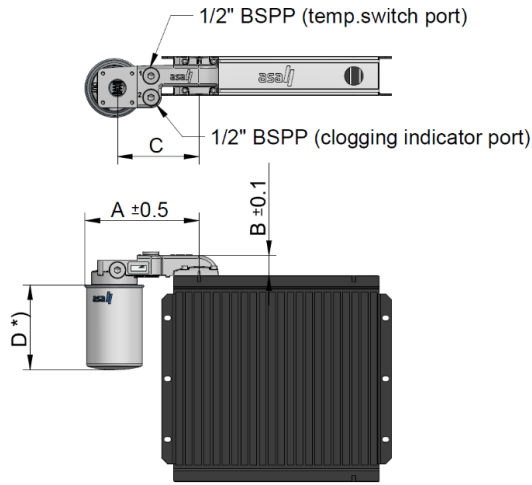

*) depending on the make of the filter element

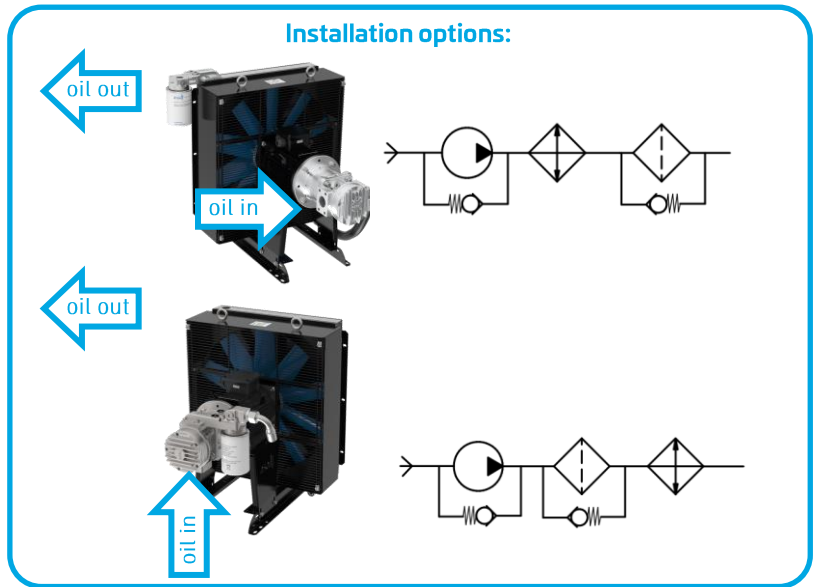

Dimension

order number	description	filter rating [μm]	working pressure [psi]	bypass [psi]	spin on port [UN]	A [in]	B [in]	C [in]	D [in]
ILLZRF11U1110U00	Spin on filter kit rail 10μm, 16gpm	10	145	30	1-12 UNF	7.42	1.30	5.31	5.75
ILLZRF11U1125U00	Spin on filter kit rail 25μm, 16gpm	25	145	30	1-12 UNF	7.42	1.30	5.31	5.75
ILLZRF12U1110U00	Spin on filter kit rail 10μm, 26gpm	10	145	30	1-12 UNF	7.42	1.30	5.31	7.52
ILLZRF12U1125U00	Spin on filter kit rail 25μm, 26gpm	25	145	30	1-12 UNF	7.42	1.30	5.31	7.52
ILLZRF21U2410U00	Spin on filter kit rail 10μm, 50gpm	-	145	30	1 ½-16 UN	8.98	1.85	6.30	-
ILLZRF21U2425U00	Spin on filter kit rail 25μm, 50gpm	-	145	30	1 ½-16 UN	8.98	1.85	6.30	-

Rail-Filter Block

material:	aluminium
working temperature range:	-4°F to +212°F (oil temperature)*
Sealing to rail flange:	o-ring NBR
bypass:	incl. 30 psi bar standard setting

Hydraulic Connection

compatible to	any rail system cooler
---------------	------------------------

Application

main application	offline circuits, lubrication, cooling and filtration circuits
oil flow	from cooler to filter

Options

temperature switches	ILLZTH5069KU00 (122°F), ILLZTH4765KU00 (122°F) ILLZTH6065KU00 (140°F)
clogging indicator / indication pressure 21.8 psi	electric: HFZVEG15KU00 N.O. & N.C.contact optical: HFZVOG15KU00

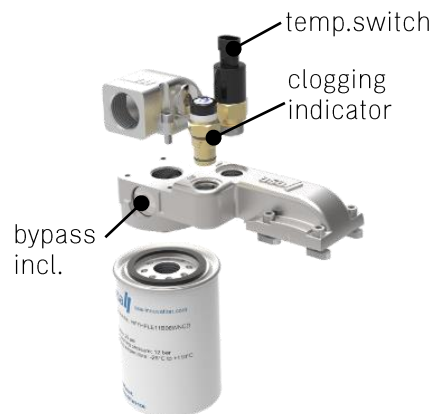

*...the indicated temperature is the maximum inlet temperature for the cooler radiator.
Depending on the sealings in use, the application needs appropriate checking.

This data sheet and the corresponding scale drawings are to be used as a general guideline and technical overview of our products. Please contact us if more exact information is needed. As we are constantly improving our products, their characteristics, dimensions and weights may also change, although we do our best to incorporate these changes continually. asa assumes no liability for any information therein, any errors, omissions, misprints, nor any direct or indirect damages, losses or costs resulting therefrom. Any cooling performances and general technical values indicated in this catalogue are measured at a test bench according to asa testing procedures or calculated, based on such tests. They represent a basis for your product selection. Due to different conditions in testing and application environments the performance may also vary by +/- 15%. All sound values are determined in accordance with ISO 9614-2, DIN EN ISO 11203 accuracy class 3 or Machinery Directive 2006/42/EG and are A-rated. At some of the performance data, possible differences to competition data are possible. The reason to that are no existing standardized testing procedures on individual subjects, e.g. for cooling performance measurements. Therefore, we recommend all products to be checked under the system operating conditions. This is also true of vibrations and mechanical stress as well as for pressure peaks and thermal stress and any other relevant factors. General tolerances according to DIN ISO 2768-M, General tolerances for casted parts according to EN ISO 8062-3 (DCTG 10). Tolerances for rubber parts are according to ISO 3302-1 (class M4-F+C). The tolerances of welding seams are defined by quality group D according to EN ISO 10042, if it is not specified on the actual scale drawing or data sheet. Any form of liability is excluded for the information included in this datasheet. All details and calculation values are checked to the best of our ability, but these do not ensure any intrinsic product properties; due to the wide-ranging possible applications, it is advised that all technical data herewith included be confirmed through testing carried out by the end-user. asa technology Produktions- und Vertriebs GmbH reserves the right to modify the product without any separate notification. This refers to both technical data and the product itself. Furthermore, it is herewith specified that the datasheet does not substitute the corresponding scale drawings, assembly and installation guidelines, nor the operating instructions.

DD-CC-2-TT-Rail-us-rev0 © asa technology, May 2024 page 6/8

OFFLINE Coolers

Air Cooled Range / Options



The thermal bypass valve is an accessory to our oil/air coolers with the asa rail system, also for easy retro fit on existing coolers in the field with internal bypass.

The function is to keep the cooling performance to a minimum on a permanent fan drive system avoiding unwanted cooling at cold start conditions. The valve opens the bypass channel below 122°F and closes for maximum oil flow through the oil channels above 122°F to 140°F. Moreover the function of a spring loaded bypass valve is also integrated to protect the radiator core in case of overpressure and high return oil flows e.g. when differential cylinders are used.

Dimension on top of cooler

(mounted on asa rail system)

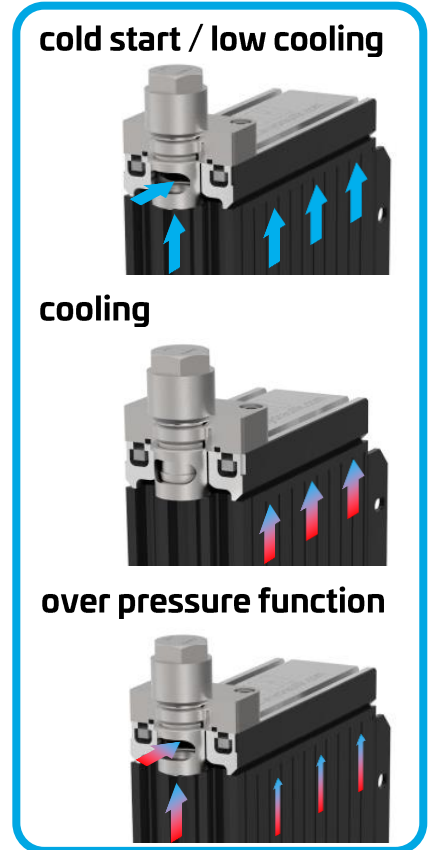
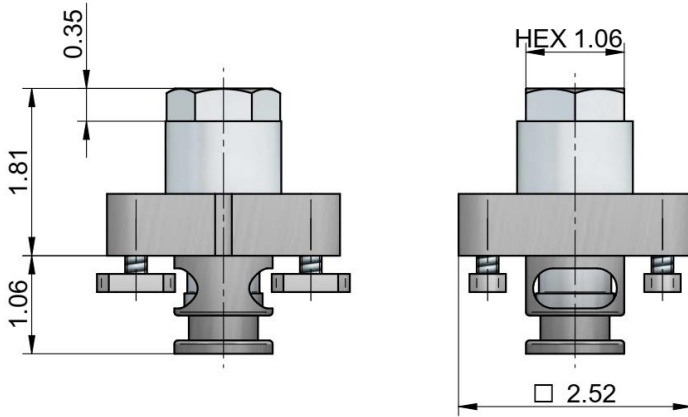

Technical Data

order number	description	max. working temperature	relief temperature	closing temperature	relief pressure	max. working pressure (static)	weight
			[°F]	[°F]	[psi]	[psi]	[lbs]
ILLZBPT5027KU00	Thermo-BP valve 122°F, TT rail	176°F	< 136	122 to 140	70*	370	1.05

*...opens only if temperature bypass is closed (≥140°F)

Materials

sealings	NBR
rail flange	aluminium
corrosion protection	all exposed surfaces: zinc-nickel plated

Availability

ILLZBPT5027KU00	rail system coolers TT25, TT36
-----------------	-----------------------------------

Compatibility

minimum fluid cleanliness	class 20/18/15 acc. to ISO 4406:1999
viscosity range:	45...2315 SSU at 100°F (10...500 cSt) recommended 70,...1155 SSU at 100°F (15...250 cSt)

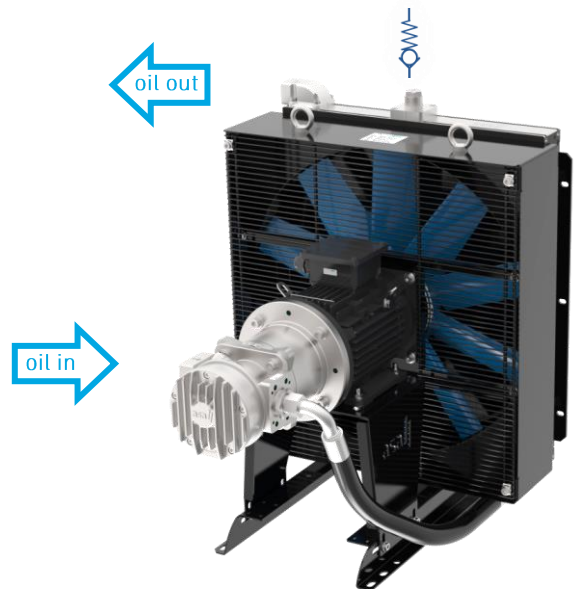

This data sheet and the corresponding scale drawings are to be used as a general guideline and technical overview of our products. Please contact us if more exact information is needed. As we are constantly improving our products, their characteristics, dimensions and weights may also change, although we do our best to incorporate these changes continually. asa assumes no liability for any information therein, any errors, omissions, misprints, nor any direct or indirect damages, losses or costs resulting therefrom. Any cooling performances and general technical values indicated in this catalogue are measured at a test bench according to asa testing procedures or calculated, based on such tests. They represent a basis for your product selection. Due to different conditions in testing and application environments the performance may also vary by +/- 15%. All sound values are determined in accordance with ISO 9614-2, DIN EN ISO 11203 accuracy class 3 or Machinery Directive 2006/42/EG and are A-rated. At some of the performance data, possible differences to competition data are possible. The reason to that are no existing standardized testing procedures on individual subjects, e.g. for cooling performance measurements. Therefore, we recommend all products to be checked under the system operating conditions. This is also true of vibrations and mechanical stress as well as for pressure peaks and thermal stress and any other relevant factors. General tolerances according to DIN ISO 2768-mS, General tolerances for casted parts according EN ISO 8062-3 (DCTG 10). Tolerances for rubber parts are according to ISO 3302-1 (class M4-F+C). The tolerances of welding seams are defined by quality group D according to EN ISO 10042, if it is not specified on the actual scale drawing or data sheet. Any form of liability is excluded for the information included in this datasheet. All details and calculation values are checked to the best of our ability, but these do not ensure any intrinsic product properties; due to the wide-ranging possible applications, it is advised that all technical data herewith included be confirmed through testing carried out by the end-user. asa technology Produktions- und Vertriebs GmbH reserves the right to modify the product without any separate notification. This refers to both technical data and the product itself. Furthermore, it is herewith specified that the datasheet does not substitute the corresponding scale drawings, assembly and installation guidelines, nor the operating instructions.

DD-CC-2-TT-Rail-us-rev0 © asa technology, May 2024 page 7/8

**be different.
make a difference.**

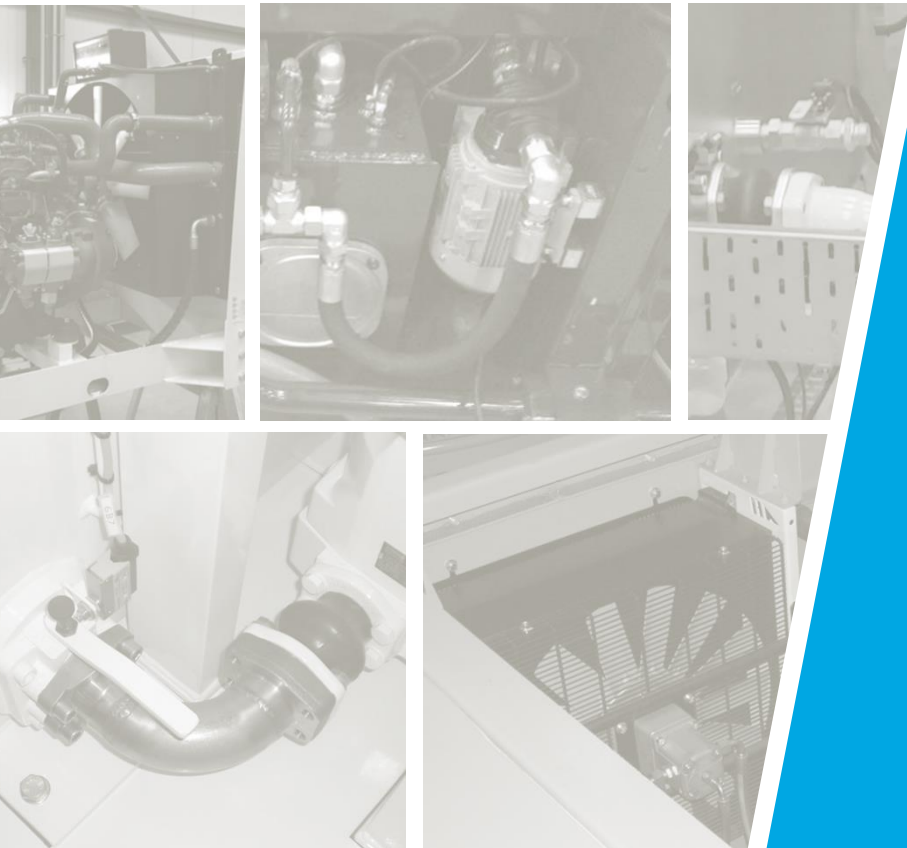

AUSTRIA

asa technology Produktions-
und Vertriebs GmbH
Prager Strasse 280
A-1210, Vienna
Tel.: +43 1 292 40 20
support@asahydraulik.com

AUSTRALIA

asa Products Pty Ltd
Quinlan Road 23
3076 Epping, Victoria
Tel.: +61 3 9397 6129
melbourne@asahydraulik.com

BRASIL

asa hydraulik do Brasil Ltda
Rua Maria Fett 96 Bloco B
03263-000 Vii Mercedes, Sao Paulo
Tel.: +55 11 9 2893-9670
sales_brazil@asahydraulik.com

CHINA

asa Hydraulik Technology (Suzhou) Co.Ltd
江苏省苏州市工业园区方洲路128号6区B幢
Area 6, Building B,
Fangzhou Road No 128,
Suzhou industrial park,
Suzhou City, Jiangsu Province
Tel.: +86 512 62381988
suzhou@asahydraulik.com

INDIA

asa heatexchanger Pvt Ltd
Plot no.1226, Phase-3, GIDC, Vatva
Ahmedabad - 382445
Tel.: +91 70 43907273
salesindia@asahydraulik.com

USA

asa hydraulik of America
160 Meister Avenue 20 A
Branchburg, New Jersey 08876
Tel.: +1 800 473 94 00
Tel.: +1 908 541 15 00
sales_us@asahydraulik.com