



H-Cube System

hydraulic oil conditioning
cooler • filter • oil tank • fan drive



discover the
customized
standard.

H-Cube Series

modular cooler, filter, tank and control link



Main features and benefits of the H-Cube system

The H-cube is a modular system, which offers three tank sizes with four oil/air cooler sizes, various fan drive types and a suction or return line filter. With its compact dimensions and the flexibility of cooling performances and oil tank volumes, this system can easily be set up in various hydraulic applications. Choose from our big range of accessories to customize the product package in detail, to your application!

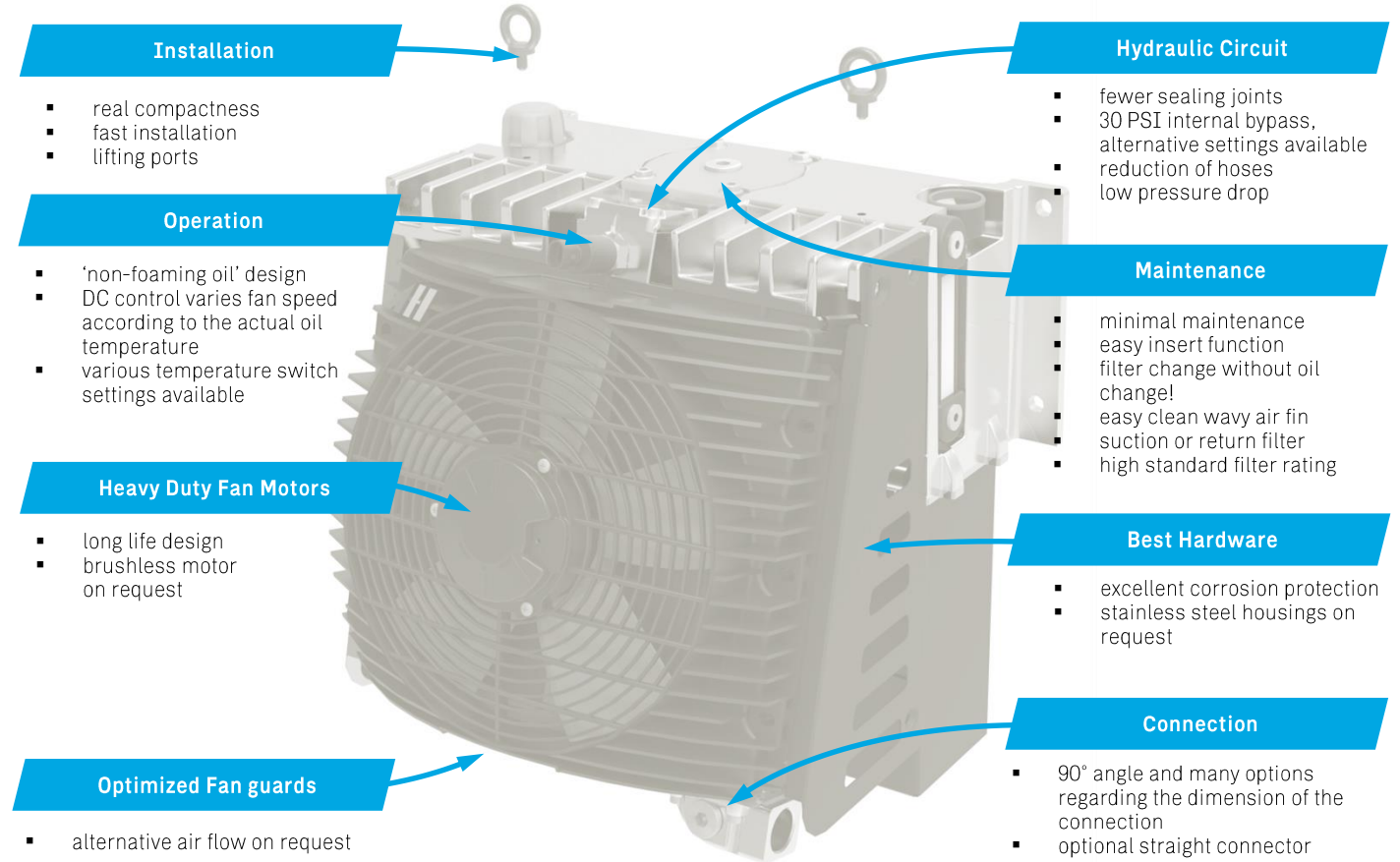

Applications

Due to the flexible design concept, the H-cube system can be configured to various applications. One main benefit is, that the H-cube system can be flanged directly onto the framework of a truck, as well as transverse to the driving direction.

- live floor trailers
- front axle drive service unit
- silo transporters
- liquid tankers like crude oil trucks
- food & chemical transporters
- compressor drive systems
- ...



direct mounting or transverse to truck frame!

This data sheet and the corresponding scale drawings are to be used as a general guideline and technical overview of our products. Please contact us if more exact information is needed. As we are constantly improving our products, their characteristics, dimensions and weights may also change, although we do our best to incorporate these changes continually. asa assumes no liability for any information therein, any errors, omissions, misprints, nor any direct or indirect damages, losses or costs resulting therefrom. Any cooling performances and general technical values indicated in this catalogue are measured at a test bench according to asa testing procedures or calculated, based on such tests. Due to different conditions in testing and application environments the performance may also vary by +/- 15%. Because there is no standardized testing procedure, tests used by other manufacturers could have different results. Therefore we recommend all products to be checked under the system operating conditions. This is also true for vibrations and mechanical stress as well as for pressure peaks and thermal stress and any other relevant factors. General tolerances according to DIN ISO 2768-v. General tolerances for casted parts according EN ISO 8062-3 (DCTG 10). Tolerances for rubber parts are according to ISO 3302-1 (class M4-F+C). The tolerances of welding seams are defined by quality group D according to EN ISO 10042, if it is not specified on the actual scale drawing or data sheet. In addition to that we point out that any data sheet and corresponding scale drawing is no substitution for the manual.

H-Cube Series

modular cooler, filter, tank and control link



Design your own H-cube!

The integration block connects tank, filter and heat exchanger. These components can be, individually, varied in size and function. As a result of that, the system is able to customize to the application, while keeping a proven standard range product. Also integrated are tank level gauge, bypass valve, clogging indicator and temperature switch port. Due to this flexible system, all parts can be combined with the same control flange. The table below shows the possible options. An enquiry number can be created by connecting the actual article codes.

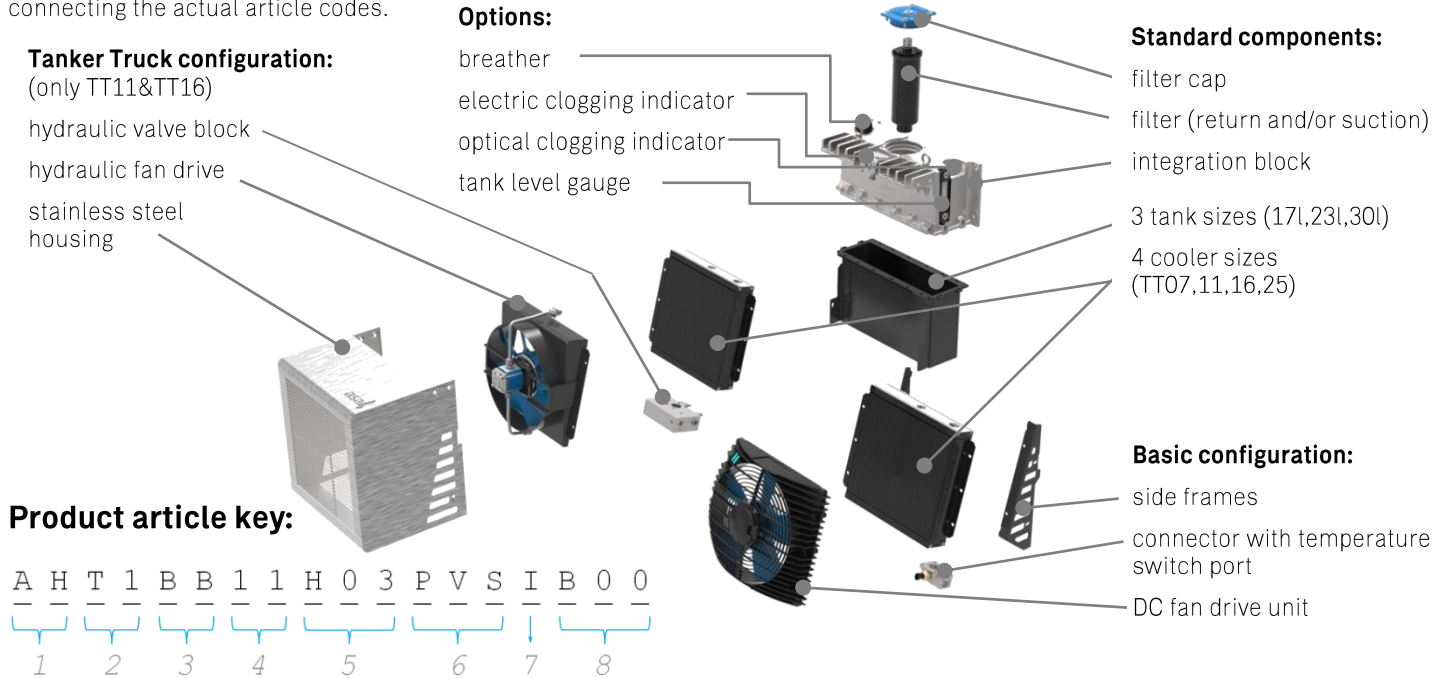

Product article key:

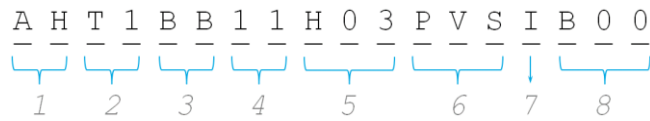

1 Product Series

AH	ASA H-Cube
----	------------

2 Tank Size*

T1	tank with 17l (EU**)
T2	tank with 23l (EU**)
T3	tank with 30l (EU**)
R5	tank with 4.5gal (US**)
R6	tank with 6.1gal (US**)
R8	tank with 7.9gal (US**)

3 Filter Combinations

	return filter	suction filter
00	none	none
B0	6µm	none
C0	10µm	none
D0	16µm	none
E0	25µm	none
OB	none	90µm standard
BB	6µm	90µm standard
CB	10µm	90µm standard
DB	16µm	90µm standard
EB	25µm	90µm standard

4 Cooler Size/Type

07	TT 07 rail, 30psi bypass
11	TT 11 rail, 30psi bypass
16	TT 16 rail, 30psi bypass
25	TT 25 rail, 30psi bypass

5 Fan Drive

D01	12V DC
D02	24V DC
H03	0.16in ³ hydraulic (only tanker truck ¹⁾)

7 Clogging Indicator

0	no indicator
I	optical clogging indicator
E	electric clogging indicator

8 Index / Customized

Bxx	special / customized specifications, to be advised by asa e.g. position of connectors, special connectors, etc...
-----	---

6 Accessories & Options***

000	no options
00S	only stainless steel housing
KTO	temperature control DC
KTS	temp. control & stainless steel housing
PVS	tanker truck ¹⁾ block 3040 PSI & stainless steel housing
PHS	tanker truck ¹⁾ block 5070 PSI & stainless steel housing

* complete system content.

** EU version truck frame flange 150 x 450mm and BSP suction port

US version truck frame flange 5.5 x 17.5inch and NPT suction port

*** stainless steel and protection housing not in combination with cooler size TT 25!

¹⁾ Only in combination with cooler sizes 11 & 16. Tanker Truck configurations include the functions of a adjustable pressure relief valve for the whole hydraulic system, return line connection and hydraulic fan drive control -> see more information on the H-Cube data sheet, page 5 or contact us for further assistance.

H-Cube Series

modular cooler, filter, tank and control link



Dimensions

There are 4 different cooler sizes which can be combined with 3 different tank sizes. According to each individual combination, the dimensional drawing is different. Please see below main measurements that are invariant on that system.

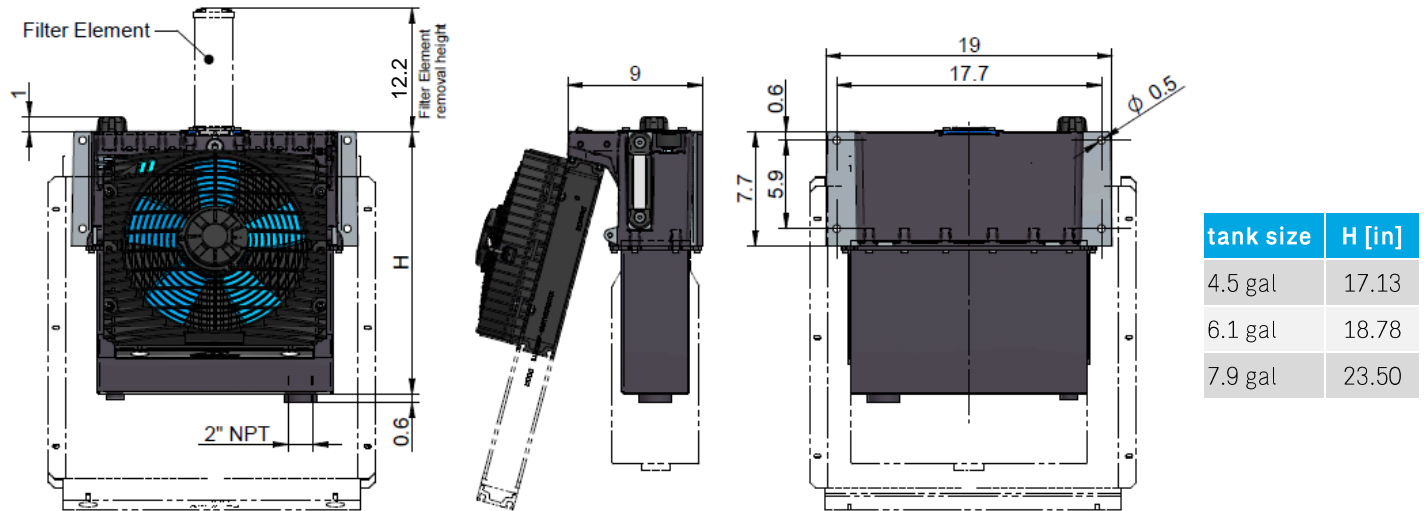

Performance Selection

The actual performance output of the H-cube system is a combination of the cooler size (radiator core) and the type of fan drive. Choose the possible performances from the table below. The shown performance is the maximum possible specific cooling performance depending on the oil flow.

Heat dissipation in HP at 144°F temperature difference and 12V fan drive

cooler type	20 gpm	40 gpm
TT 07	16	16
TT 11	26	28
TT 16	38	41
TT 25	67	71

Heat dissipation range (hydraulic drive) by pressure and oil flow

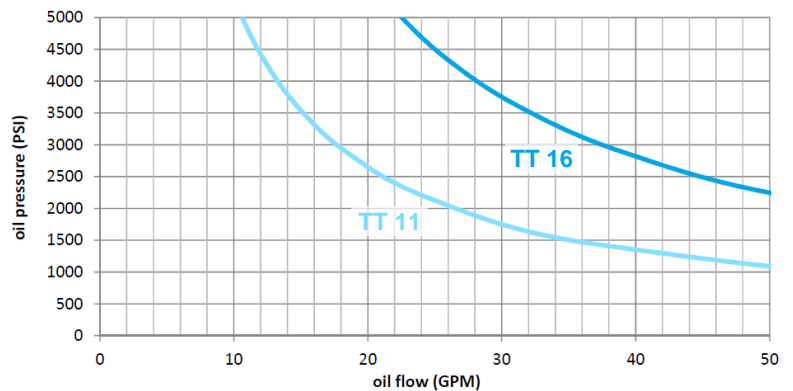

Specifications

The materials on our standard configuration are designed for mobile applications, but can also be used for industrial applications. Our high corrosion protection standard provides life time excellence to any configured package.

radiator material	brazed aluminium	standard air flow direction	pulling
radiator air fin	wavy	weight (dry)	60 lbs to max. 117 lbs
tank material	steel		
integration block	anodized cast aluminium		
return filter / suction filter	3 μ to 25 μ with 25 PSI or 44 PSI bypass		
fan drive	12V / 24V DC or hydraulic		

This data sheet and the corresponding scale drawings are to be used as a general guideline and technical overview of our products. Please contact us if more exact information is needed. As we are constantly improving our products, their characteristics, dimensions and weights may also change, although we do our best to incorporate these changes continually. asa assumes no liability for any information therein, any errors, omissions, misprints, nor any direct or indirect damages, losses or costs resulting therefrom. Any cooling performances and general technical values indicated in this catalogue are measured at a test bench according to asa testing procedures or calculated, based on such tests. Due to different conditions in testing and application environments the performance may also vary by +/- 15%. Because there is no standardized testing procedure, tests used by other manufacturers could have different results. Therefore we recommend all products to be checked under the system operating conditions. This is also true for vibrations and mechanical stress as well as for pressure peaks and thermal stress and any other relevant factors. General tolerances according to DIN ISO 2768-v. General tolerances for casted parts according to EN ISO 8062-3 (DCTG 10). Tolerances for rubber parts are according to ISO 3302-1 (class M4-F+C). The tolerances of welding seams are defined by quality group D according to EN ISO 10042, if it is not specified on the actual scale drawing or data sheet. In addition to that we point out that any data sheet and corresponding scale drawing is no substitution for the manual.
 DD-H-Cube-us-rev12 © asa hydraulik, May 2019 4/8

H-Cube Series

modular cooler, filter, tank and control link



H-Cube configuration example: Tanker Truck

The H-Cube system can also be configured with a control block for relief valve function and flow control. This system is mainly used on tanker trucks and is a very compact cooling and filtration solution for your hydraulic system.

Setup Example H-Cube R5-C0-16-H03-PVS-I

This compact and real light weight system is an efficient hydraulic control and conditioning module for continuous operation. This system allows heavy duty operation while controlling oil filtration and temperature.

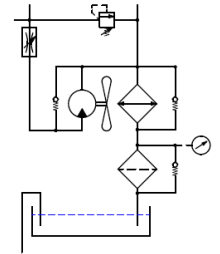

- *stainless steel housing*
- *4.5 gallon oil reservoir*
- *hydraulic fan drive with flow control*
- *relief valve*
- *return filter*
- *500 PSI to 3040 PSI (5070 PSI option)*
- *up to 60 GPM*
- *corrosion and vibration resistant*
- *pressure connection #12 SAE*
- *many customizing options...*

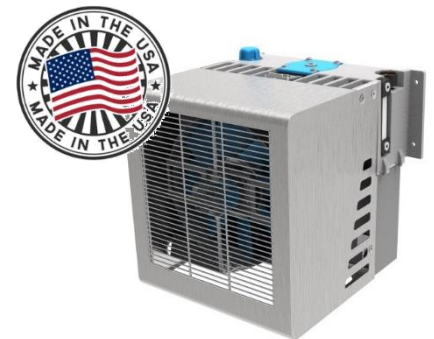
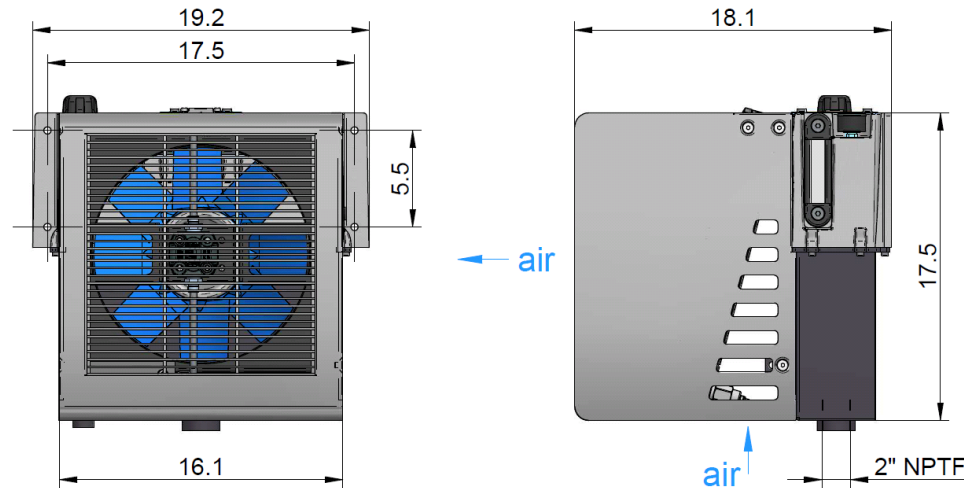
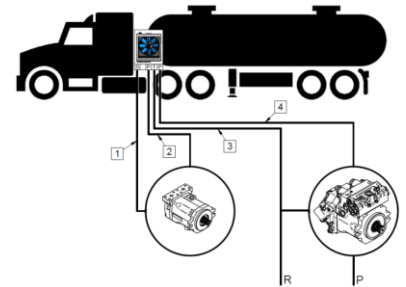

Cross Reference List for Tanker Truck Configurations

asa reference number	competitor product
H-Cube R5-C0-16-H03-PVS-I	GD MH5 Hydrapak
H-Cube R5-C0-11-H03-PVS-I	GD MH3 Hydrapak
H-Cube R5-C0-16-H03-PHS-I	PSG (Blackmer) Hydrive 2020
...contact us for further comparisons!	

Change your worn system to a new H-Cube and increase your efficiency!



This data sheet and the corresponding scale drawings are to be used as a general guideline and technical overview of our products. Please contact us if more exact information is needed. As we are constantly improving our products, their characteristics, dimensions and weights may also change, although we do our best to incorporate these changes continually. asa assumes no liability for any information therein, any errors, omissions, misprints, nor any direct or indirect damages, losses or costs resulting therefrom. Any cooling performances and general technical values indicated in this catalogue are measured at a test bench according to asa testing procedures or calculated, based on such tests. Due to different conditions in testing and application environments the performance may also vary by +/- 15%. Because there is no standardized testing procedure, tests used by other manufacturers could have different results. Therefore we recommend all products to be checked under the system operating conditions. This is also true for vibrations and mechanical stress as well as for pressure peaks and thermal stress and any other relevant factors. General tolerances according to DIN ISO 2768-v. General tolerances for casted parts according to EN ISO 8062-3 (DCTG 10). Tolerances for rubber parts are according to ISO 3302-1 (class M4-F+C). The tolerances of welding seams are defined by quality group D according to EN ISO 10042, if it is not specified on the actual scale drawing or data sheet. In addition to that we point out that any data sheet and corresponding scale drawing is no substitution for the manual.
 DD-H-Cube-us-rev12 © asa hydraulik, May 2019 5/8

H-Cube Series

modular cooler, filter, tank and control link



H-Cube configuration example: Auxiliary Truck Drive

The H-Cube system can be configured to various applications. Auxiliary truck drives are circuits to assist the drive train at low speed on gravel or other rough road conditions. Such temporary hydraulic drive circuits require a high cooling performance over a short operation period.

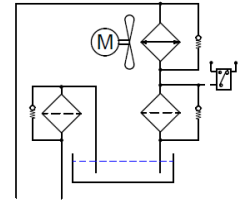

Setup Example H-Cube R5-CB-16-D01-E-B00

In this example the 4.5 gallon oil reservoir, TT 16 size cooler and filters (return and suction) have been selected. The compactness and cost savings against a conventional system with separate components proves the comprehensive efficiency of this system.

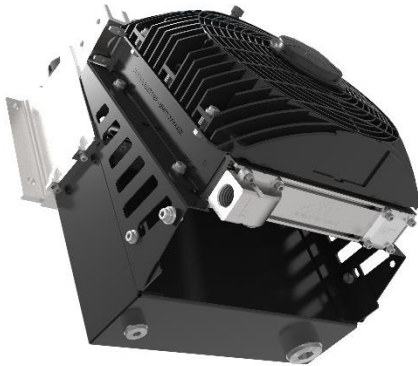

- 12V DC fan drive
- IP 68 motor protection
- 4.5 gallon oil reservoir
- return filter
- suction filter
- up to 60 GPM
- corrosion and vibration resistant
- temperature control options
- clogging indicator switch

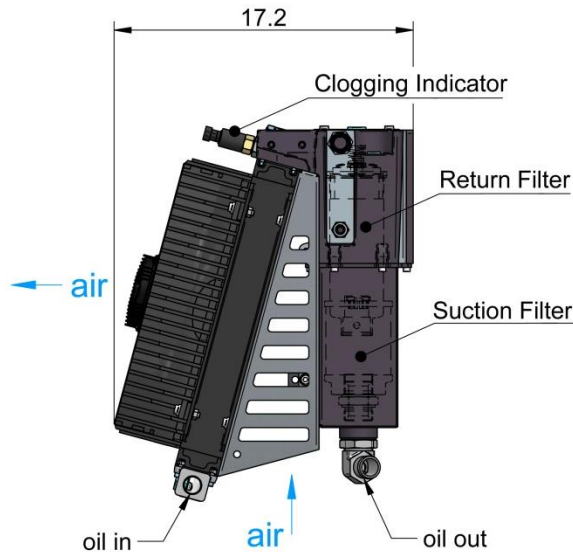
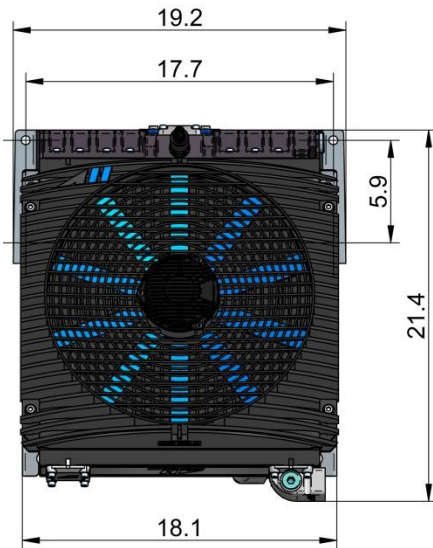
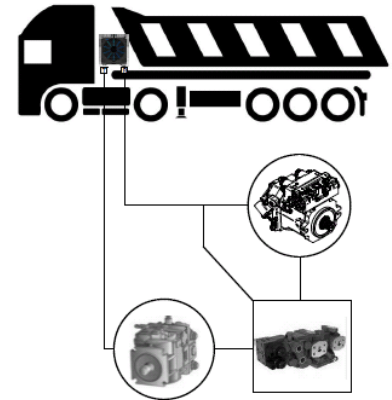

This data sheet and the corresponding scale drawings are to be used as a general guideline and technical overview of our products. Please contact us if more exact information is needed. As we are constantly improving our products, their characteristics, dimensions and weights may also change, although we do our best to incorporate these changes continually. asa assumes no liability for any information therein, any errors, omissions, misprints, nor any direct or indirect damages, losses or costs resulting therefrom. Any cooling performances and general technical values indicated in this catalogue are measured at a test bench according to asa testing procedures or calculated, based on such tests. Due to different conditions in testing and application environments the performance may also vary by +/- 15%. Because there is no standardized testing procedure, tests used by other manufacturers could have different results. Therefore we recommend all products to be checked under the system operating conditions. This is also true for vibrations and mechanical stress as well as for pressure peaks and thermal stress and any other relevant factors. General tolerances according to DIN ISO 2768-v. General tolerances for casted parts according to EN ISO 8062-3 (DCTG 10). Tolerances for rubber parts are according to ISO 3302-1 (class M4-F+C). The tolerances of welding seams are defined by quality group D according to EN ISO 10042, if it is not specified on the actual scale drawing or data sheet. In addition to that we point out that any data sheet and corresponding scale drawing is no substitution for the manual.
 DD-H-Cube-us-rev12 © asa hydraulik, May 2019

H-Cube Series

modular cooler, filter, tank and control link



Reliability in all fields

Best Warranty



We offer you a very strong warranty period of one year. This period begins on the actual start up date of the equipment, provided that date is within six month of receipt of goods. The maximum warranty from date of shipment is 18 months. Our high quality is proven by successful ISO certification on all asa production facilities.

Best Packing

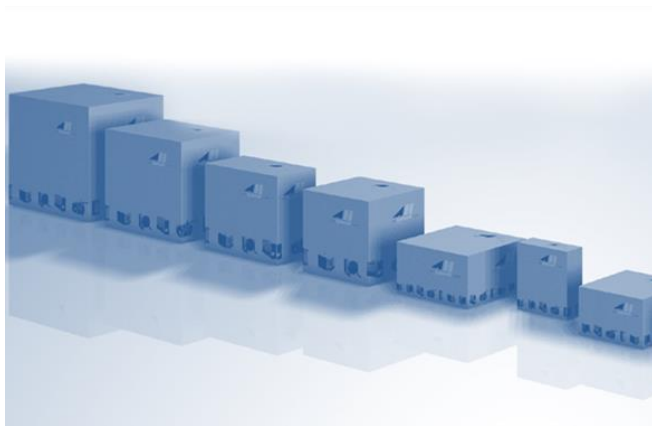

Single orders, delivery batches, containers: we help you to figure out the most economic way to transport the goods. Let us try to keep your expenses to what they are supposed for and not to the forwarding agents and useless packaging material.

Best Service



Send us your enquiries or call our head offices or distribution partners. Our goal is to support any of your requirements and wishes of technically and economic belongings. Our online calculation program has free access and is very easy to use.

Best Availability



We build your order in record time! Our unique lead time of 5 to 10 working days ex works on standard products provide the highest flexibility to your time schedule.

**be different.
make a difference.**



AUSTRIA

asa hydraulik GmbH
Prager Strasse 280
A-1210, Vienna
Tel.: +43 1 292 40 20
support@asahydraulik.com

USA

asa hydraulik of America
160 Meister Avenue 20 A
Branchburg, New Jersey 08876
Tel.: +1 800 473 94 00
Tel.: +1 908 541 15 00
sales_us@asahydraulik.com

CHINA

安飒液压科技（苏州）有限公司
asa Hydraulik Technology (Suzhou) Co.Ltd
江苏省苏州市工业园区方洲路 128 号 6 区 B 幢
Area 6, Building B,
Fangzhou Road No 128,
Suzhou industrial park,
Suzhou City, Jiangsu Province
Tel.: +86 512 62381988
suzhou@asahydraulik.com

AUSTRALIA

asa Products Pty Ltd
Bentley Street 4/15
3016 Williamstown, Victoria
Tel.: +61 3 9397 6129
melbourne@asahydraulik.com

INDIA

ASAHydraulik India Pvt Ltd
C1/109/9, GIDC, Palej, Dt.Bharuch
Gujarat - 392220
Tel.: +91 22 28195557
salesindia@asahydraulik.com